

M6x25

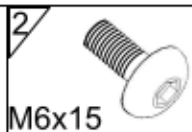

M6x15

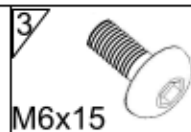

M6x15

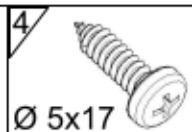

Ø 5x17



M8x16

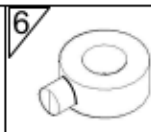

Ø 5x17



SINGLE DESK

A

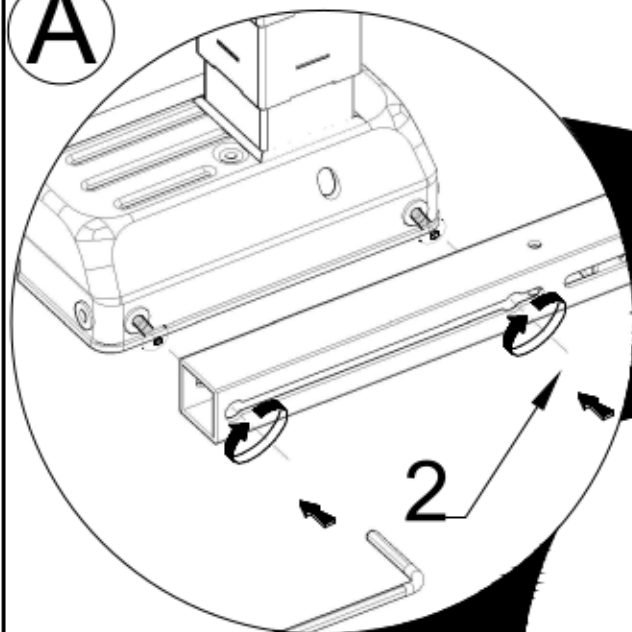

2

Przykręcić śruby z małą siłą.
Tighten the screws lightly
Serrez légèrement la vis
Ziehen Sie die Schrauben leicht an

.mdd

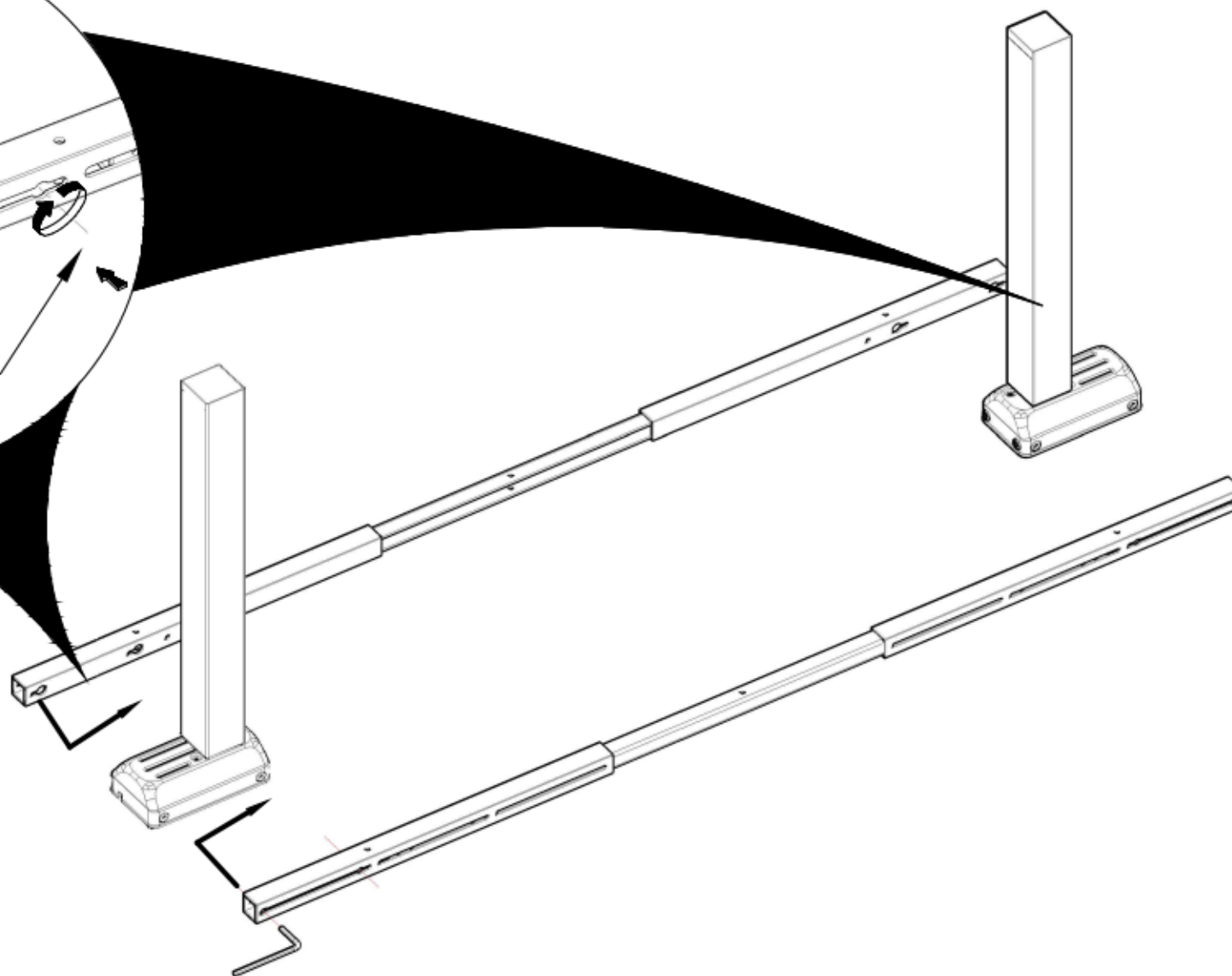

B

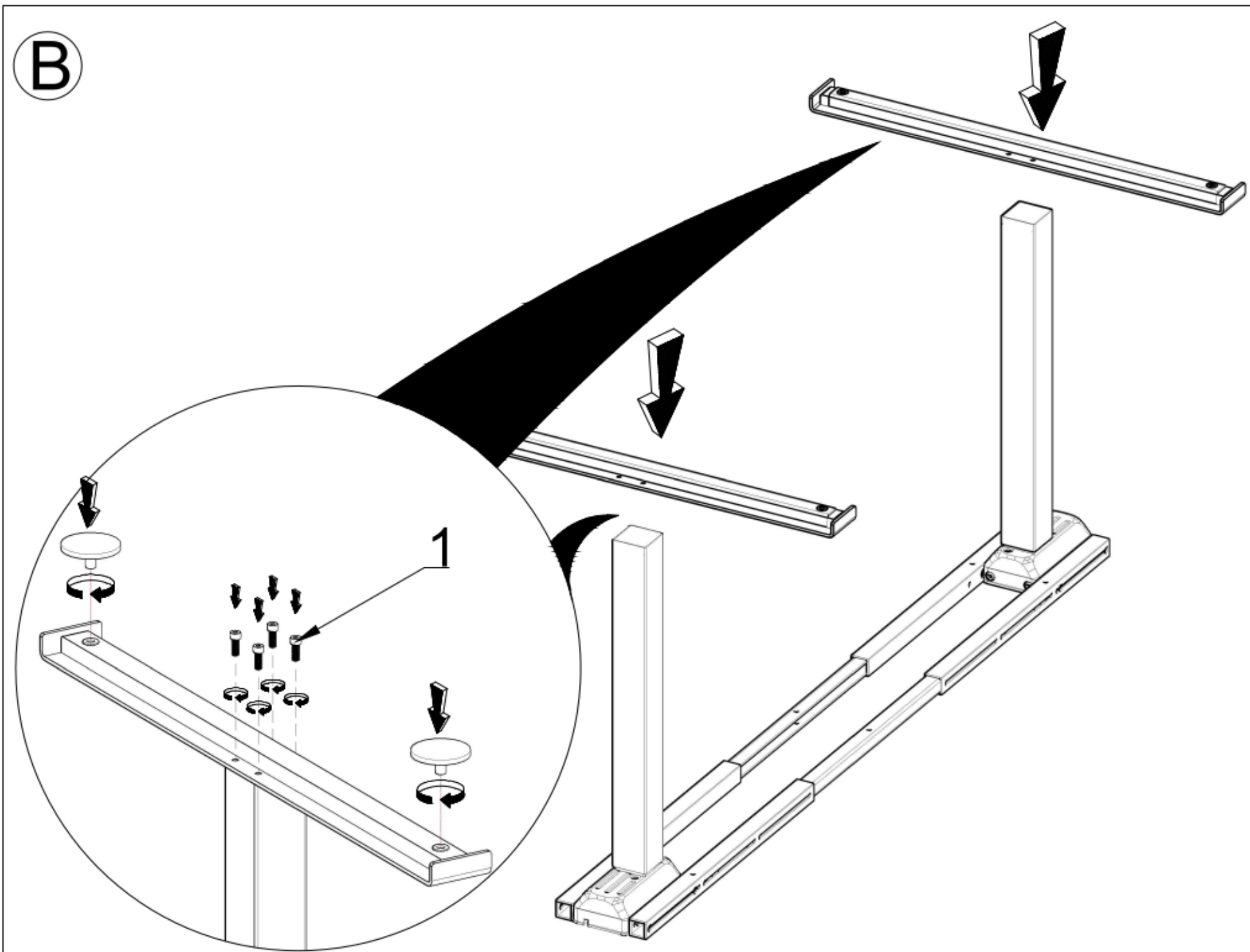

C

Dokręcić śruby z dużą siłą.
Tighten the screws firmly
Serrez fortement la vis
Ziehen Sie die Schrauben mit großer Kraft an

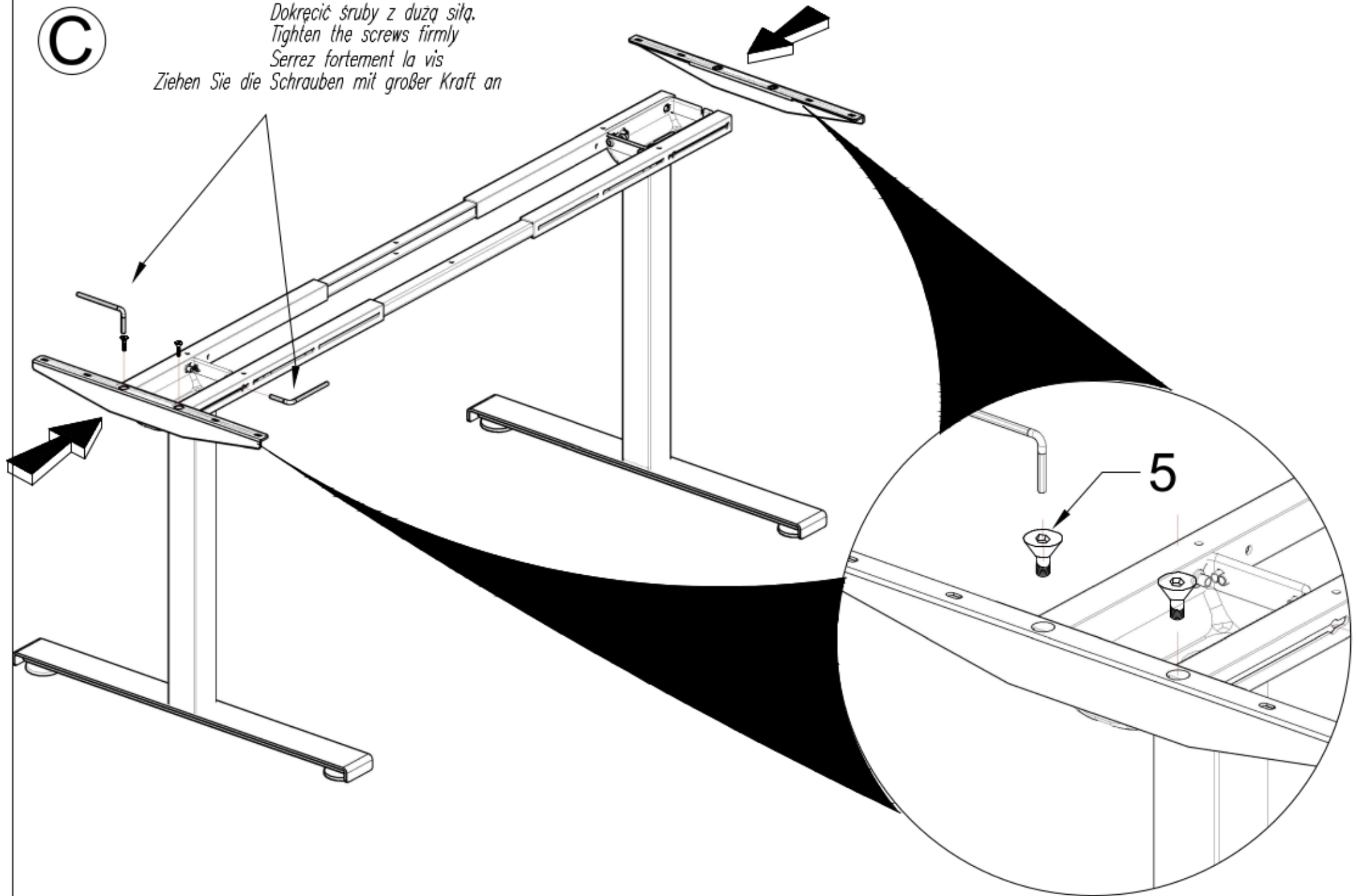

D

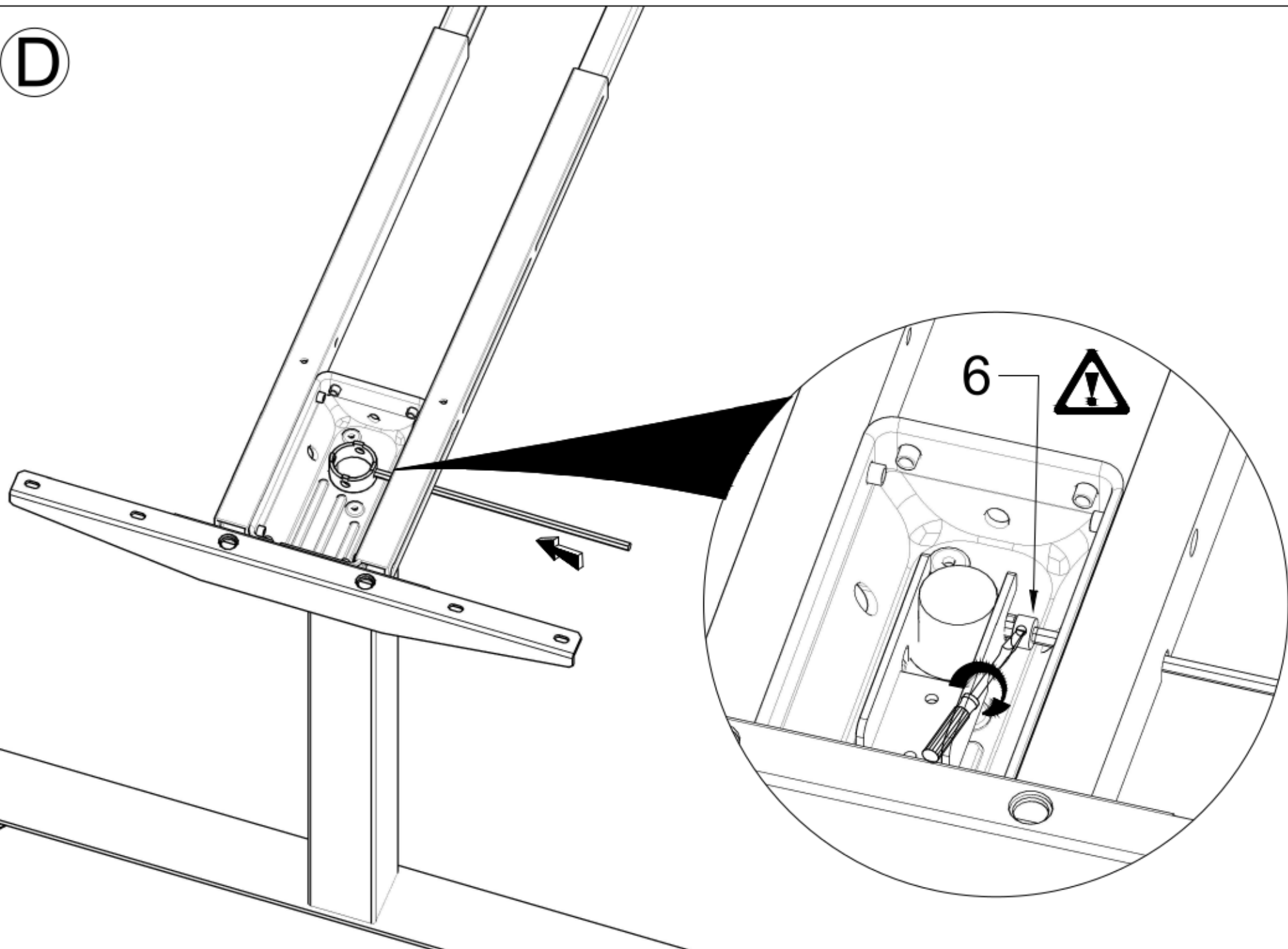

E

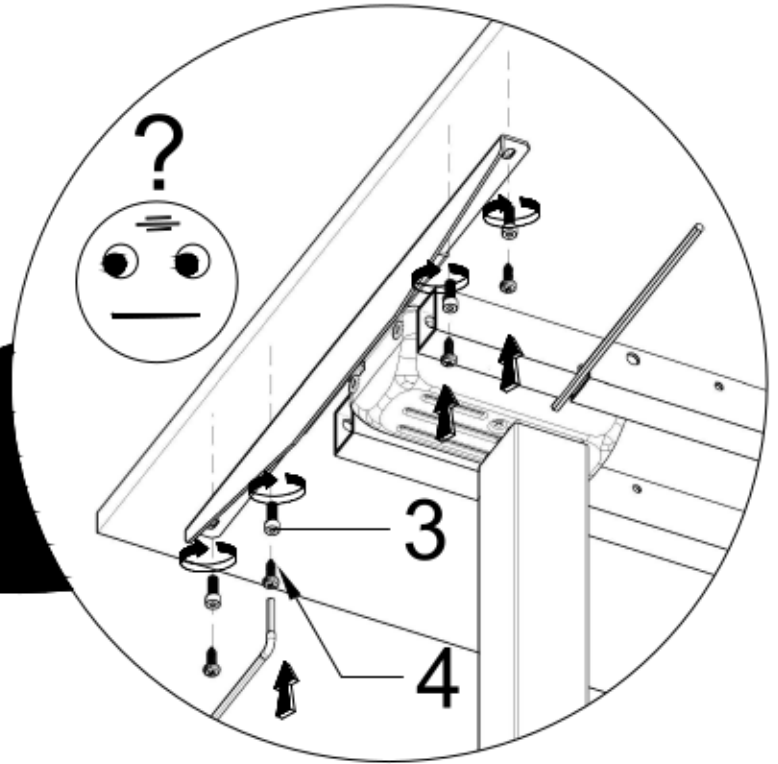
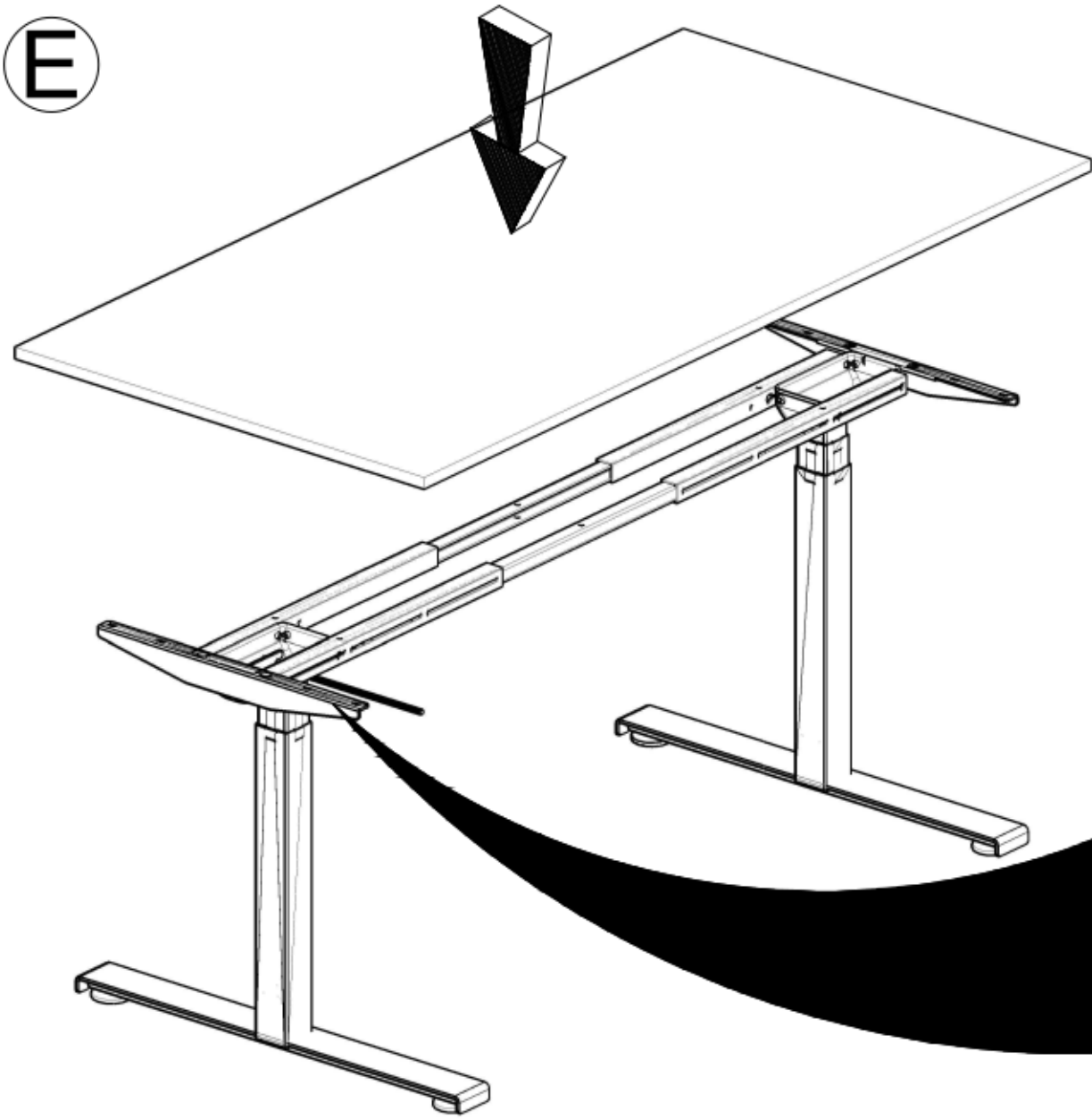

F

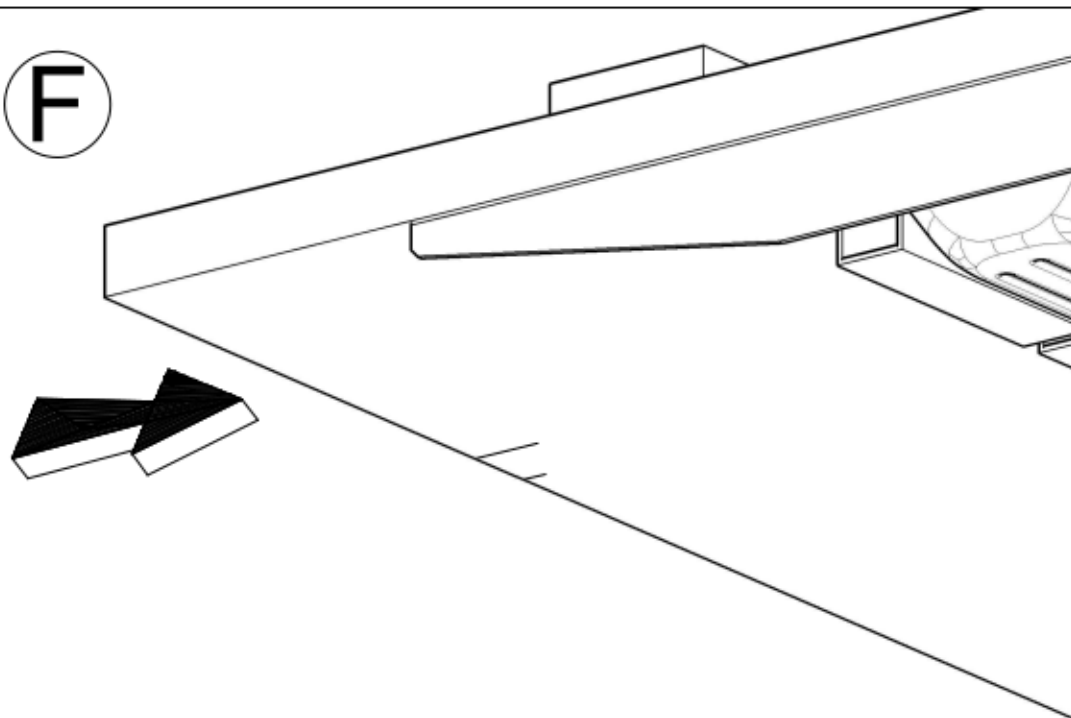

G

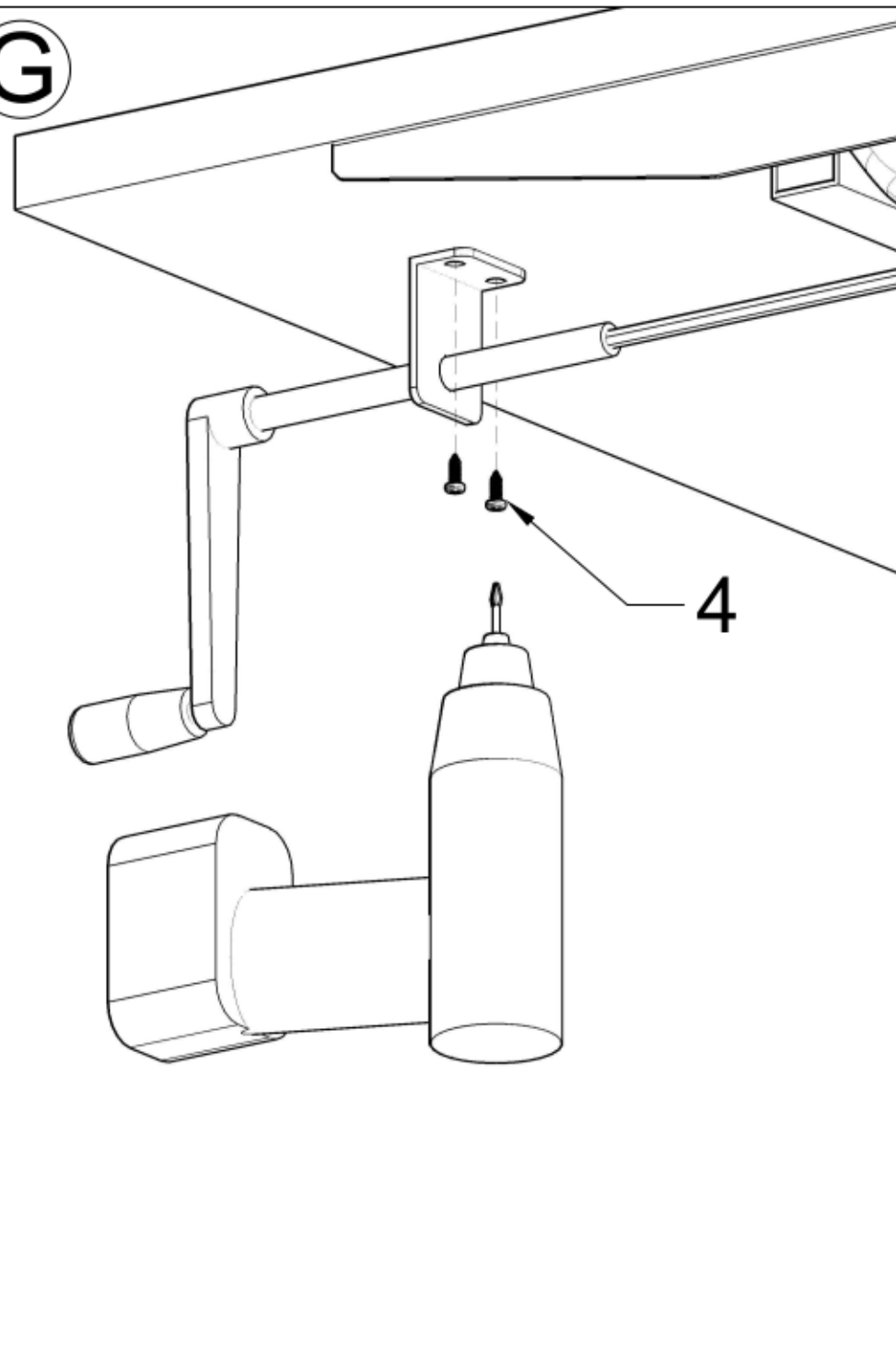

G

MAX 100 KG

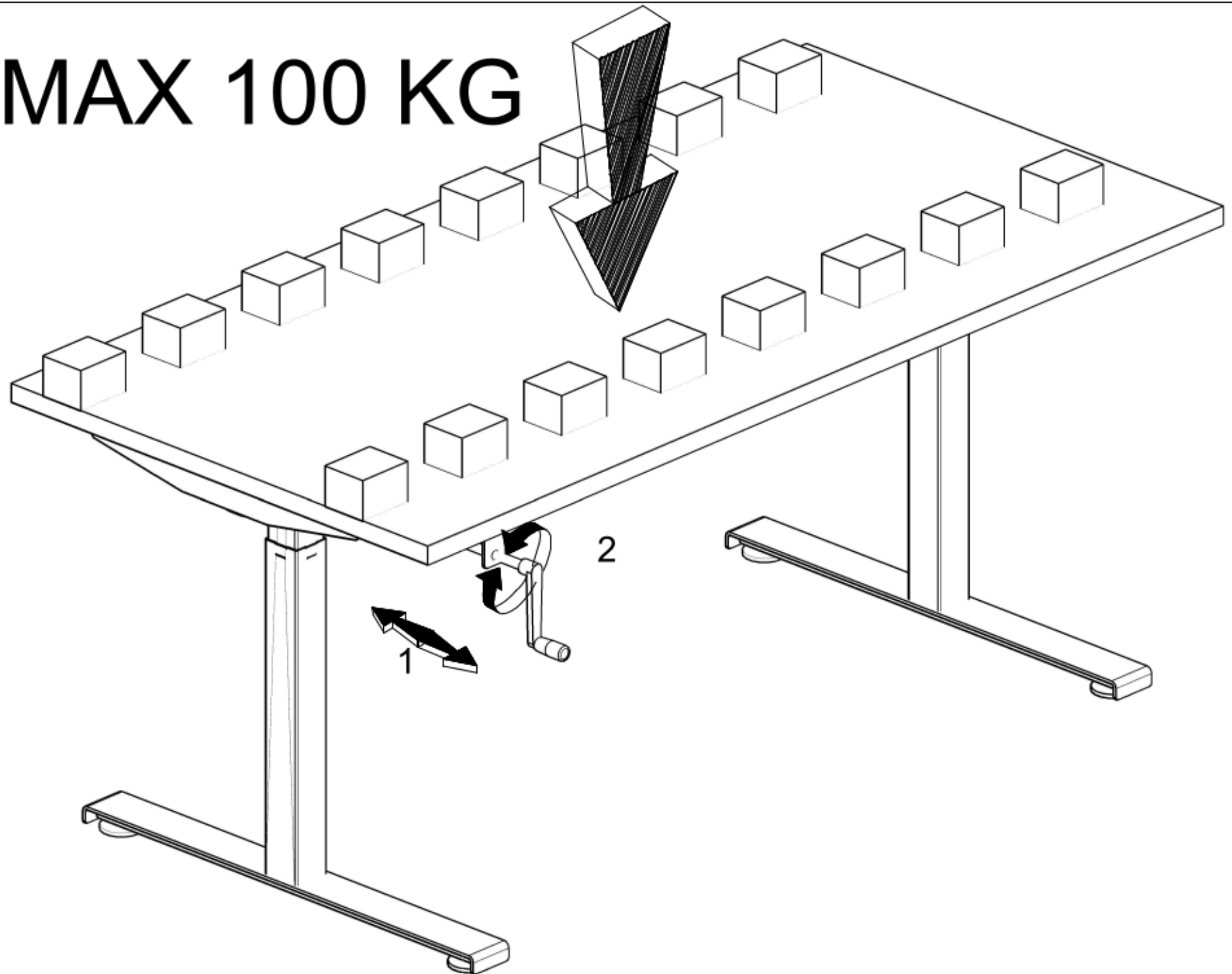

1



M05

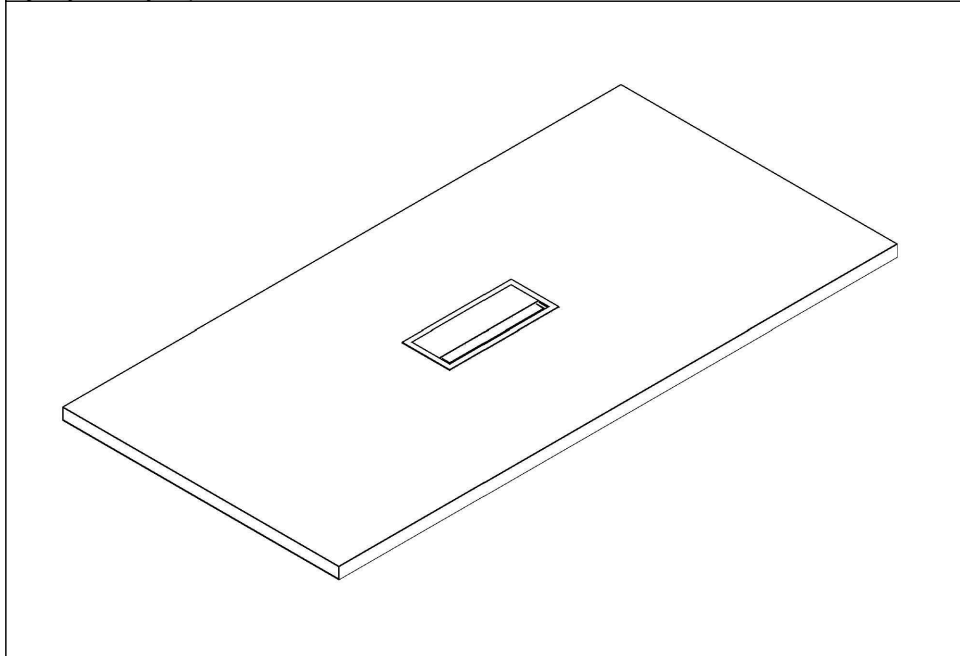
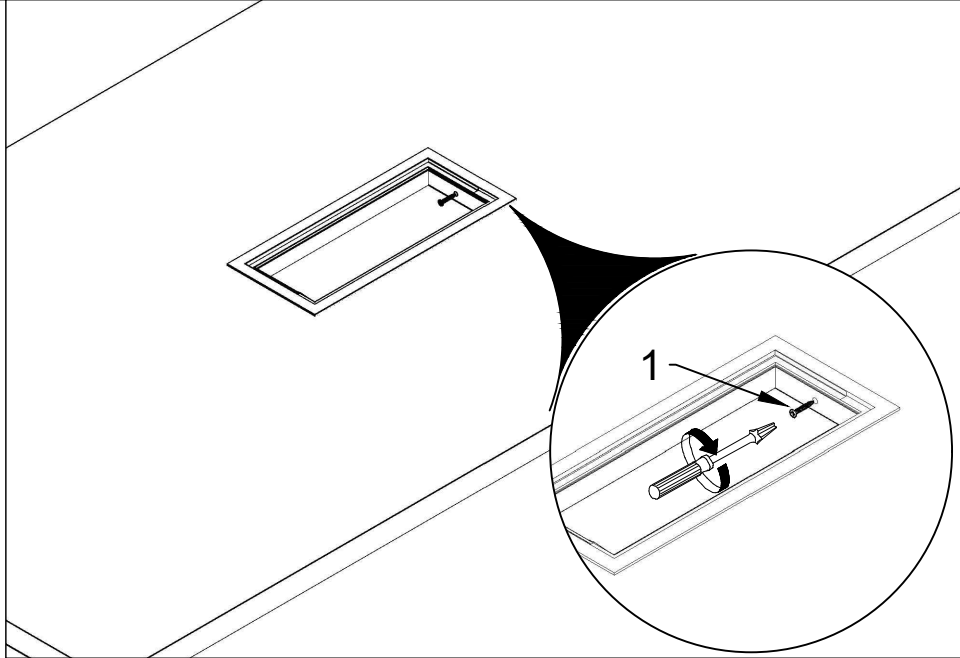
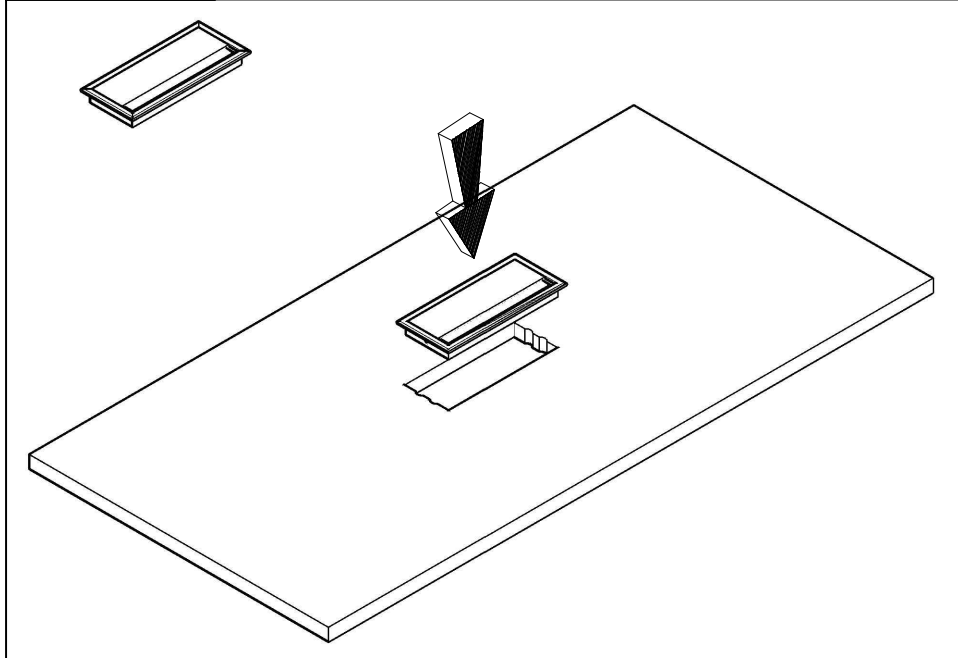

1



3x20

M04

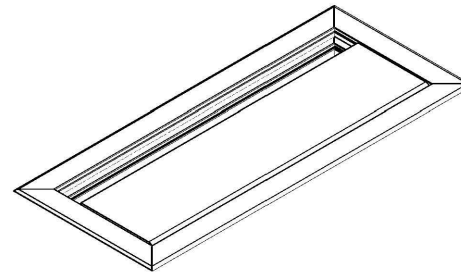
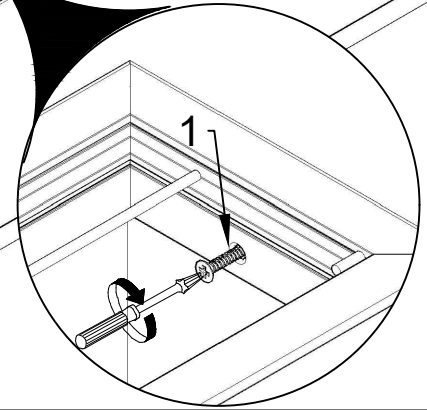
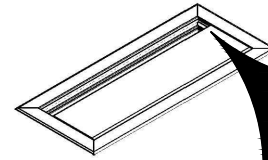
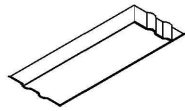
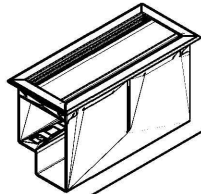
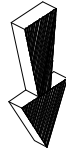

1



M04

