

ROUND

For effective workplace design

narbutas

Open vs. private

Totally open > Mostly open > Somewhat open > Shared offices > Mostly private > Totally private





Cosy, rational and comfortable workplaces offering desired levels of privacy in large open-plan offices

A perfect workplace environment ensures:

- A simple way of adding new workplaces
- A large number of workplace planning options
- A desired level of privacy



Continuity

From single desk to ceaseless unit



Variety

From regular desk row to sophisticated tracery



Adaptability

From open space for collaboration to completely private one for individual work



narbutas

Human-centred approach



narbutas



ROUND promises a win-win situation in organising workplaces in large open-place offices

Round metal tube legs –
the main distinctive design
feature of **ROUND** system





Traditional layout of workplaces

From single desk to bench desks for collaborative tasks



Enables both small and large teams to create a workspace ideal for exchanging ideas and performing collaborative tasks

Desk screens as an addition to workplaces



Desk screens are an excellent way to ensure greater level of privacy for employees, while at the same time giving them sufficient freedom to share their ideas with other team members



ROUND system elements allow creating a rational and efficient layout of workspaces

A variety of workplace layouts

- An easy way to set up different workplace benches as per needs
- Efficient workplace layout
- Convenient storage of items near the workplace
- Ensuring a required level of privacy



Modular cabinet system

Single-sided



Single-sided or double-sided cabinets give you a great degree of freedom to choose the option that works best for particular tasks



Double-sided



Defining separate workspaces

Desk-height cabinets with cut-outs for wire management

- A separate employee space is not assigned for open-contact spaces
- Encouraging cooperation between team members and continuous sharing of ideas



Single-height shelf units for placement on cabinets

- A clear vertical delineation of the space and separation of individual workplaces
- Allowing employees to maintain eye contact and encouraging interaction and cooperation
- Encouraging employees to stay involved in the office life and to engage in exchange of ideas



Two-height shelf units for placement on cabinets

- Clear delineation of employee or team space
- Ensuring visual privacy for employees while they are sitting
- Promoting greater concentration on tasks at hand



Storage solutions for individual needs



Desk-height cabinets



1H shelf units



2H shelf units

Well thought-out power solutions

Connecting a group* of workstations requires just one point of power supply on the floor or in the wall

- Easy connection of desks into a single electric circuit
- Efficient planning of electricity and data supply for workstations
- Convenient to use
- Wires and cables are hidden in the cabinet making your workplace look tidy and well-organised



*EU – up to 6, US – up to 4 workplaces.

Wide range of applications



Conform to the EU, FR, UK, CH, and USA standards

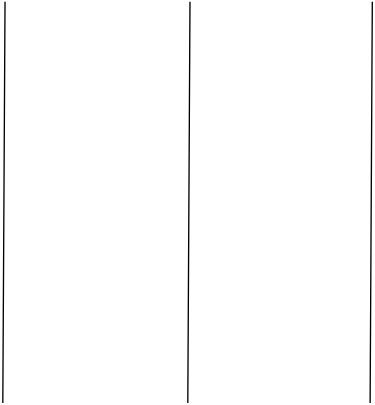

LAN

USB

220V



LAN modems



mini-UPS systems

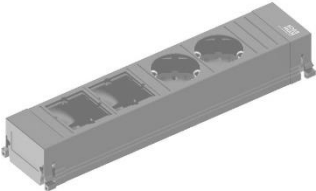

power blocks

oelectrics
always innovating

Convenient access to power supply



Metal cover with rounded edges

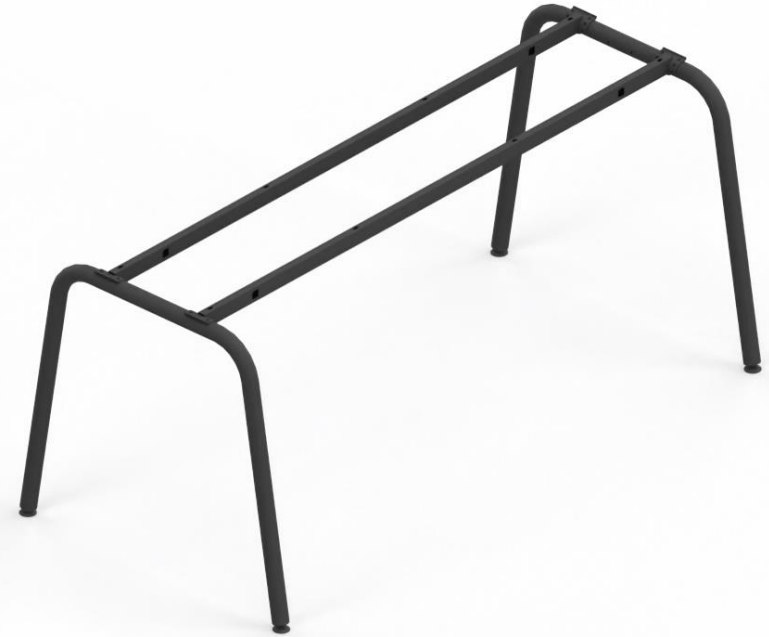

Cable tray for wire management

Examples of power management in the workplace

1.

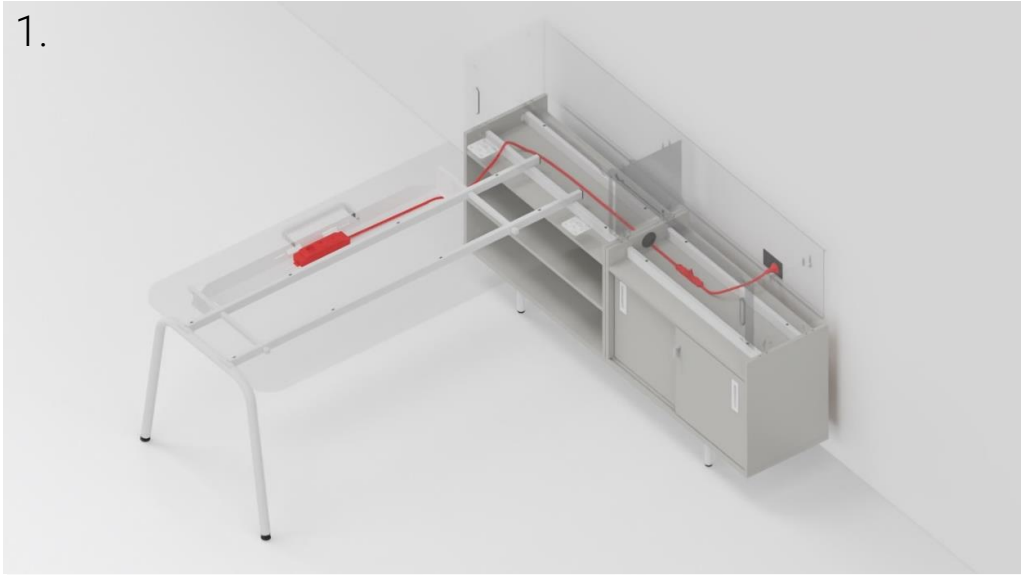

2.

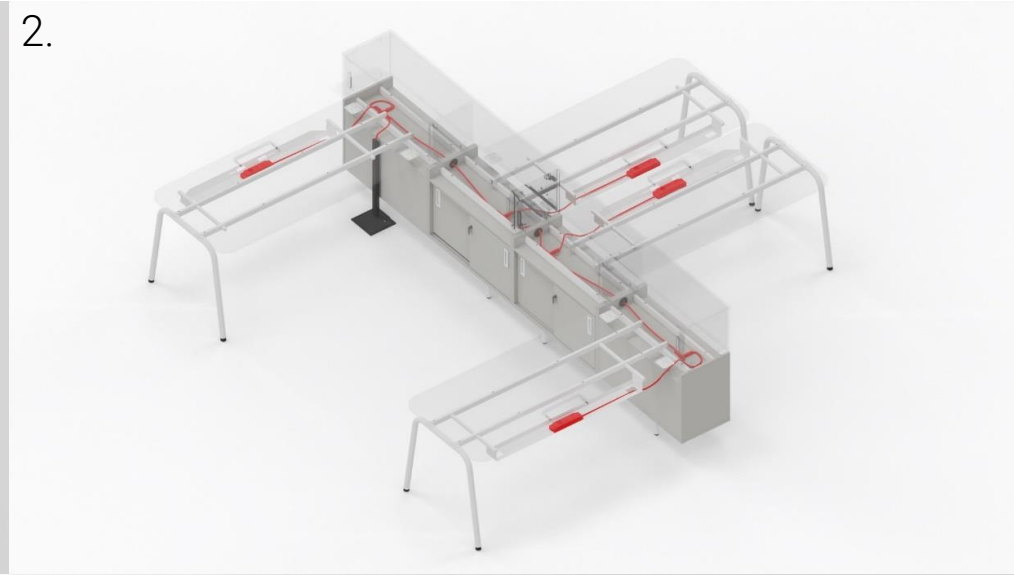

3.

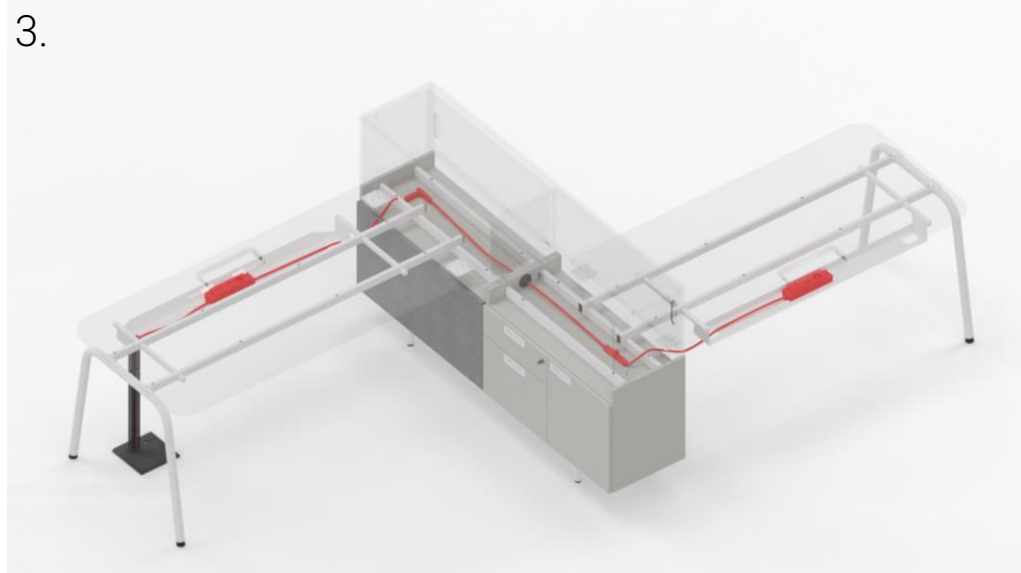

4.

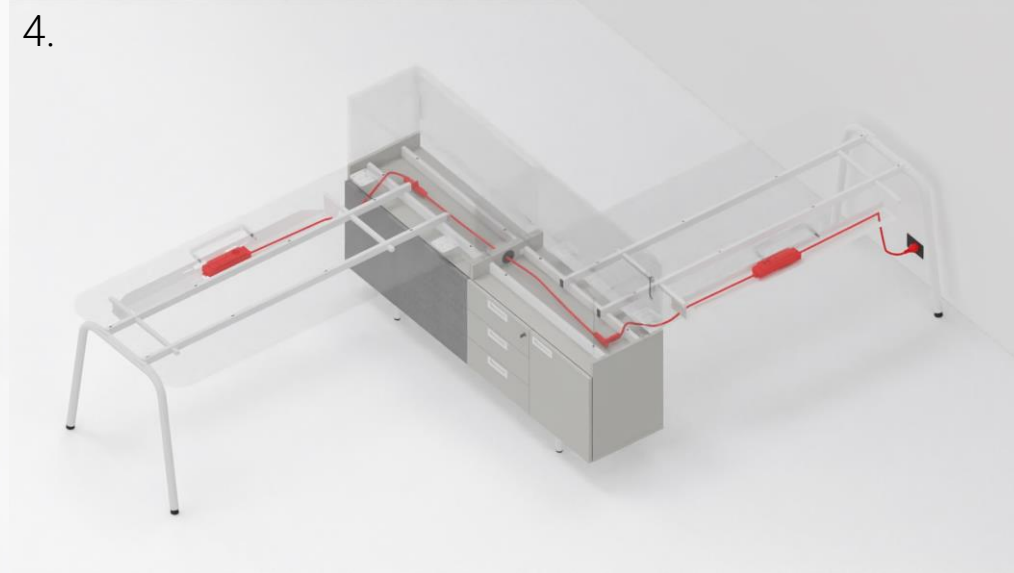

1. From the wall/column to the cabinet

2. From the floor to the cabinet

3. From the floor to the desk cable tray (via the vertical cable tray) and from there to the cabinet

4. From the wall/column to the desk cable tray and from there to the cabinet

What type is your office layout?

Cellular office (individual workplaces)



A



B

What type is your office layout?

Open office (bench desks)



A



B

What type is your office layout?

Semi-private space ("office in the office")



A



B



C

Countless possibilities





narbutas