

Technical specification

1 Seat - metal frame filled with foam,
density of 55 kg/m³, upholstered

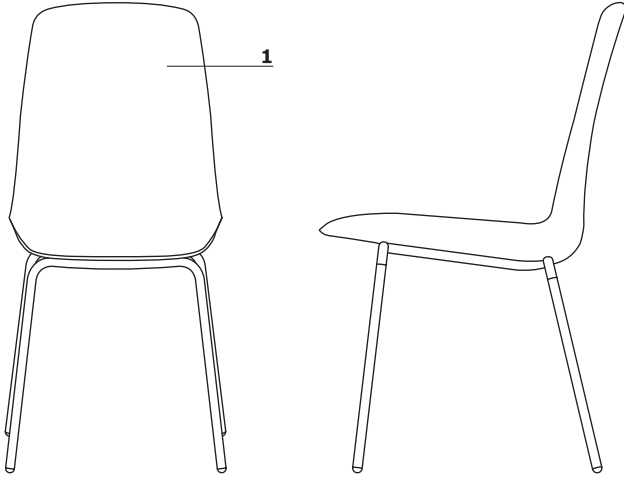

- max. load 120 kg

Bases

1 Base UKP16:

- 4 - legged, metal, powder coated
- legs made of tube Ø18 mm, wall thickness 2 mm, CNC - bent
- legs finished with polypropylene feet

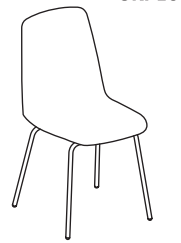
**2 Base UKP17:**

- 4 - star, metal, powder coated
- swivel seat - 360°
- legs made of tube Ø22 mm, wall thickness 2,5 mm, CNC - bent
- legs finished with polypropylene feet

**3 Base UKP18K:**

- 4 - star, metal, powder coated
- fixed seat
- legs made of tube Ø22 mm, wall thickness 2 mm, CNC - bent
- castors for soft floors
- OPTION WITH EXTRA CHARGE - castors for hard floors

**4 Base UKP22:**

- 5 - star, aluminum, Ø=630 mm, h=360 mm, powder coated
- swivel seat - 360°
- gas spring, steel, colour: black, adjustment range 120 mm (450 - 570 mm)
- castors for soft floors
- OPTION WITH EXTRA CHARGE - castors for hard floors

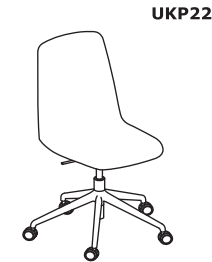
**5 Base UKP9:**

- 4 - star, wooden, Ø35 mm
- beechwood coated with transparent varnish
- swivel seat - 360°
- metal legs - connecting elements, colour: black semi-matt

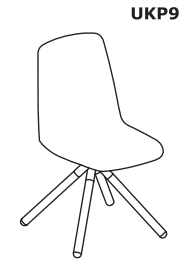
**1 Base UKP19, UKPP19:**

- 4 - star, aluminum, powder coated
- swivel seat - 360°
- aluminium cast
- legs finished with polypropylene feet

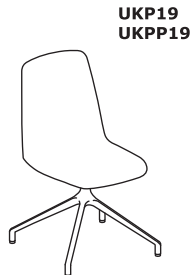
**2 Base UKP19K, UKPP19K:**

- 4 - star, aluminum, powder coated
- swivel seat - 360°
- aluminium cast
- castors for soft floors
- OPTION WITH EXTRA CHARGE - castors for hard floors



Dimensions (mm)

UKP18K

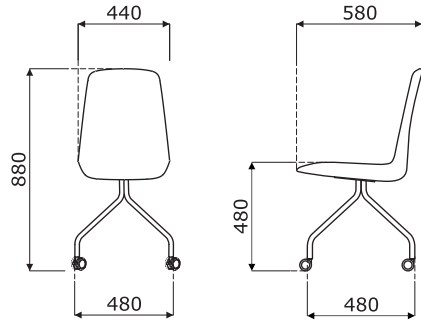

UKP17

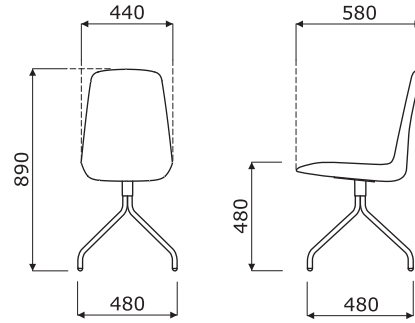

UKP16

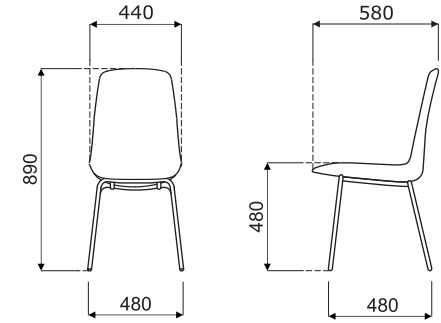

**UKPP19
UKP19**

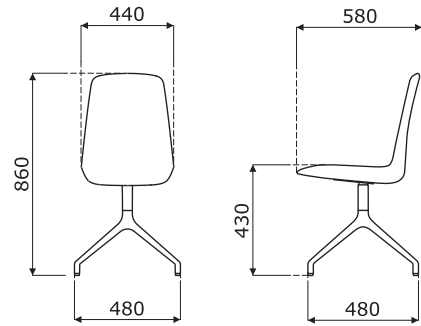

**UKPP19K
UKP19K**

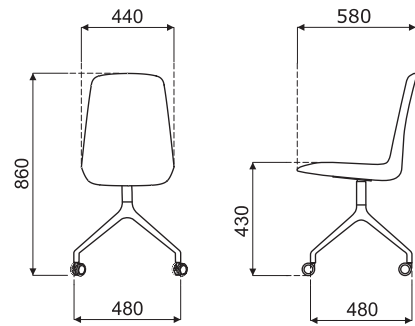

UKP9

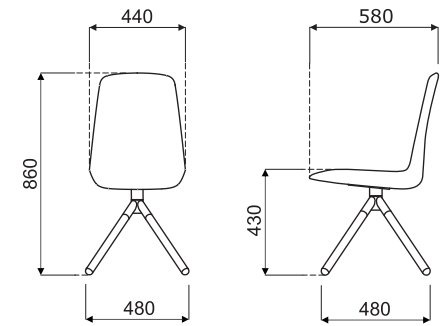

UKP22

